



dan-bos - ApS

tel: +45 97 92 61 00 fax: +45 97 92 61 00

www.secondhand-equipment.com

Vaccum pump and weighing system for gentle handling of fish



Easy To Operate

Easy to operate. Hoses may be placed on top of the machine. Connect the pump to an electrical outlet and it is operational.



Supporting Leg Adjustment

The strong and adjustable supporting leg makes it easy to place the pump and move it from pond to pond.



Gentle Pumping

A large suction funnel and custom-built clutches provide gentle pumping. The funnel is fitted with rubber protection to ensure the fish is unharmed during suction.

<http://www.danbos.com>

Phone: + 45 97 92 61 00, e-mail info@danbos.dk , Industrivej 19 b-c, DK-7700 Thisted, Denmark



Separator Box

The fish is separated from the water by a large grill separator before weighing and sorting. The water is led back into the pond.



Constant pumping

The pump itself is a simple construction, which leads to more reliable operation and fewer repairs. The containers may be tilted to provide constant pumping and they operate without the use of electronics. This prevents operational failures caused by frost, humidity and the ingress of water into vulnerable parts. The materials used are stainless and hot galvanized for extra long life. The pump has sound absorption.

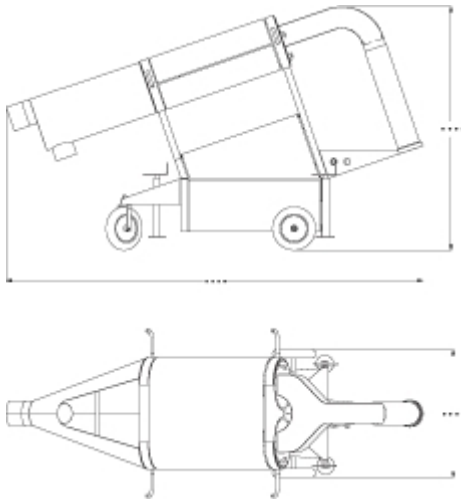

Capacity of Pump	0-16 t/h
Fish size	0-5000 g
Suction height	5000 mm
Containers/inlets	2 x 150 ltr/190 x 190 mm
Suction hose	152 x 6000 or 200 x 6000 mm
Fish outlet	230 mm
Return water outlet	200 mm
Water separator	0,6 square metres
Grill distance	8 mm
Engine	4 kw 3 x 380 v
Wheels with ball bearings	3 (16x650-8)
3 supporting legs	450 mm (adjustable)
Fish outlet height	900 - 1500 mm
Total height	2300 mm
Total width	1550 mm
Total length	3600 mm
Weight	650 kg

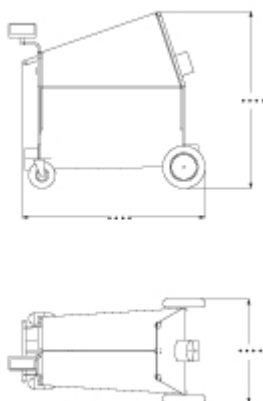

Capacity Fish Weight	6 t/hour
Fish size	0-1200 g
Fish outlet	200 mm
Engine	0,09 kw 3 x 380 v
Wheels with ball bearings	2 (400-8) 2 (350-4)
Weight unit	50 g
Total height	1650 mm
Total width	1030 mm
Total length	1650 mm
Weight	190 kg